

GPSdome 1.02B

Anti-Jammer

DATASHEET

GPSdome: Industry's Only Non-ITAR GPS Anti-Jammer

GPSdome is a small-sized, add-on device that provides protection against GPS jamming, ensuring continuity of autonomous navigation and operation during jamming conditions. No other solution that offers such protection is as small, light, affordable or as easily installed as GPSdome.

Applications

With GPS as the cornerstone of navigation, military systems can be completely disabled by simple GPS jammers available online today for less than \$50.

GPSdome is suitable for a wide variety of GPS-dependent applications. GPSdome is a small sized, light weight, low powered solution suitable to be retrofitted to protect any navigation system. With GPSdome's protection, any military system immediately becomes more robust and protected against wireless attacks.

Features

- Null steering technology
- Small form factor: 70 x 48 x 24mm, 150 g
- Minimal power consumption: <0.75W
- IP67, -40°C to +85°C

How GPSdome Works

GPS Vulnerabilities Are Well Known: Orbiting at 20,000KM above sea level, the GPS satellites emit a signal which is incredibly weak when received by GPS receivers (~-125dBm). To jam this signal, all one has to do is overpower it, either with a simple jammer bought online, which blocks it completely, or with slightly more sophisticated hardware that can trick it with erroneous data.

The Null Steering Algorithm was originally developed for military applications to protect wireless signals. GPSdome adds our own sophisticated algorithms and proprietary RFIC to detect suspicious signals, combine antenna patterns and precisely target a null in the direction of the hostile signal.

Installation Couldn't Be Easier: After mounting both antennas on a flat, sky facing base at least half a wave-length apart (10cm minimum, 20cm is optimal), connect antennas to GPSdome, connect it to the antenna input on your GPS receiver, feed it with power and you're set to go.

Jamming Detection is available from an LED on the GPSdome itself or via an external wire that could be integrated into any system computer.



GPSdome 1.02B

Anti-Jammer

DATASHEET



Specification Summary

Dimensions

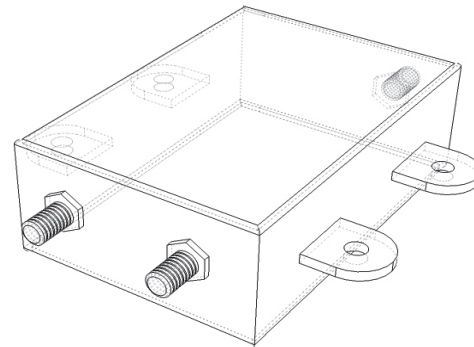
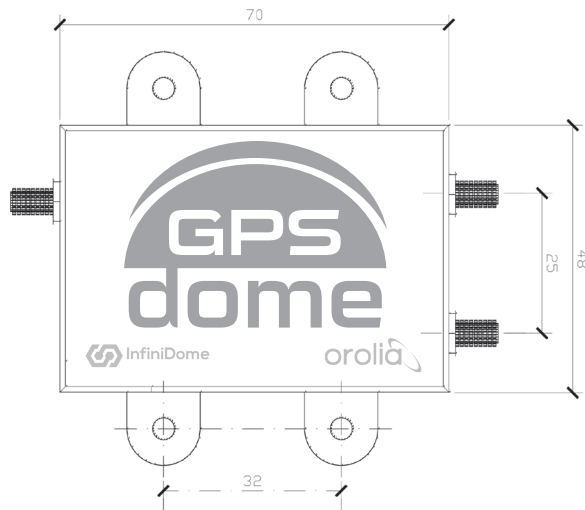

Physical	
Enclosure	70mm x 48 mm x 24mm (excluding mounting lugs)
Weight	150g
Mounting	4 x M3 bolts (not supplied)
Environmental	
Operating Temperature Range	-40°C to 85°C
Protection	IP67
Interfaces	
Primary Antenna Input (P)	50Ω SMA 2.75VDC designed for 26dB ±2dB gain
Auxiliary Antenna Input (A)	50Ω SMA 2.75VDC designed for 26dB ±2dB gain
Power Input	50Ω SMA *3.3VDC – 32VDC 0.75W *not for EPS option

Performance	
Protected Signal	1575.42 MHz (GPS L1 C/A Code)
Latency	100ns ±15ns (fixed)
Compression Point	25dBm
Insertion Loss	6.5dB ±2dB

Safety & Compliance	
R&TTE 1999/5/EC : EN60950-1 EN301 489-1 EN301 489-3 EN300 440-2	1575.42 MHz (GPS L1 C/A Code)
RoHS compliant	
WEEE registration number WEE/GK2929WW	

EPS Wire Connection	
Red: 3.3VDC – 32VDC	
Black: GND	
Brown: Open drain interference indication	

Ordering Information

CAT NO	DESCRIPTION
Gpsdome 1.02B PPS	Standard Product – VDC is supplied from the (R) connector
Gpsdome 1.02B EPS	Additional 2.15m 3 wire cable for 3.3VDC – 32VDC feed and Interference Indication



www.orolia.com | sales@orolia.com